

Insertion Technology Main Features

- All the insertion technology flow sensors are velocity-based flow measurement devices.
- The installation typically requires only a small hole in the pipe for sensor perpendicular mounting.
- Sensors' dimensions are not pipe size specific: almost independent from pipe cross section.

Insertion Technology Theory

Insertion technology is based on fluid speed meters, properly installed in a cylindrical straight pipe, and used to measure the local flow velocity V_m to calculate the average velocity V_a and the volumetric flow rate Q_v .

These flow sensors are theoretically supported by fluid-dynamic laws applicable to any circular cross section pipe when some physical conditions (fully developed turbulent flow) are respected.

Those laws state the relationship between the measured local flow velocity and the average flow velocity (UNI 10727; ISO 7145).

The relationship between average velocity V_a and measured velocity is usually expressed through the "Profile Factor":

$$F_p = V_a / V_m$$

Using the above mentioned factor:

$$Q_v = V_a * ID^2 / 4 = F_p * V_m * ID^2 / 4$$

ID = pipe inside diameter

Two different positions are suitable for the flow velocity measuring point:

1. Critical position: the velocity sensor is inserted in a peculiar point where the local velocity correspond to the average velocity:

$$V_a = V_m \Rightarrow F_p = 1.$$

2. Central position: the velocity sensor is placed exactly in the centre of the pipe cross section. The local velocity correspond to the maximum velocity:

$$V_m = V_{max} \Rightarrow F_p < 1.$$

Fully Developed Turbulent Flow

All velocity based flow sensors provide an accurate and reliable indication only when they are measuring a fully developed turbulent flow. Fully developed turbulent flow occurs in every Newtonian fluid when the Reynolds Number is greater than 4500.

Fully developed turbulent flow can be more difficult to achieve with high viscosity liquids, low flow rates or large pipes.

Quite often a reduction of the pipe size to increase the local flow velocity is enough to produce a proper Reynolds Number:

$$Re = V \times ID \times Sg / \mu$$

where:

- V = flow velocity in m/s
- ID = pipe inside diameter in meter
- Sg = Specific Gravity in Kg/m³
- μ = Dynamic Viscosity in Pa*s (1 Pa*s = 10³ cP)

or, converting flow velocity in flow rate:

$$Re = 1.2732 \times Q_v \times Sg / \mu \times ID$$

where:

- Q_v = flow rate in l/s
- Sg = Specific Gravity in Kg/m³
- μ = Dynamic Viscosity in Pa*s (1 Pa*s = 10³ cP)
- ID = pipe inside diameter in meter

$$Re = 3162.76 \times Q_v \times Sg / \mu \times ID$$

where:

- Q_v = flow rate in gpm
- Sg = Specific Gravity in Kg/m³
- μ = Dynamic Viscosity in centipoises (1 Pa*s = 10³ cP)
- ID = pipe inside diameter in inches

Flow Sensor Installation

The placement of a flow meter is critical to get an accurate and reliable reading. For a flow meter proper performance it is necessary to check:

- full pipe at every time
- uniform flow velocity into the pipe.

Full Pipe Condition

If the pipe is not full the flow meter will give inaccurate reading even if the sensor is always completely submerged. The meter will make the flow rate calculation on the assumption that the pipe is full, leading to overestimation of the flow. A pump intake or an outlet on the bottom of a tank does not necessary ensure the pipe always running full; air can be sucked by pumps or it could remain entrapped when the pipe was empty.

Anyway the flowmeter should be always situated in the lowest point of the pipe and there should be downstream the flowmeter a part of the pipe placed 1 x ID higher than where the flow meter is located.

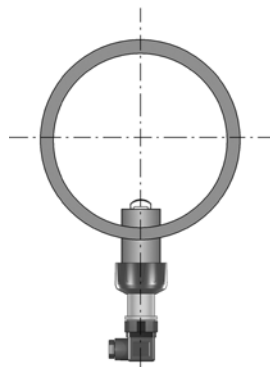

Fig. 1

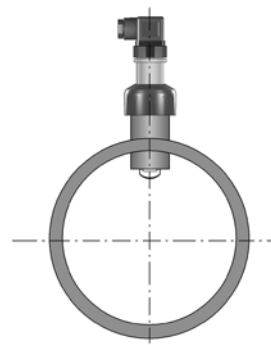

Fig. 2

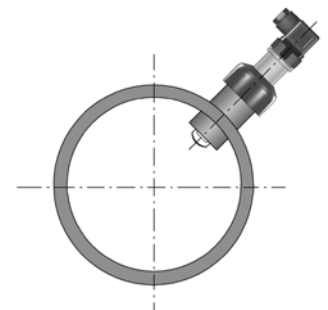

Fig. 3

Mounting Positions

The reading accuracy of paddlewheel flow sensors can be also affected by sediments present into the liquid and by mounting angle due to the effect of gravity increasing the friction between shaft and bearings.

- Horizontal pipe runs: the mounting position to get the best performances is vertical or at a maximum 45° angle to avoid air bubbles. Do not mount the sensor on the bottom of the pipe if sediments are likely.
- Vertical pipe runs: install sensor in any orientation. Upward flow is preferred to ensure full pipe.

Uniform Flow Velocity

Insertion flow meters measure the velocity of the liquid. It is important the velocity is uniform across the entire cross section of the pipe in the location of the sensor. Flow patterns are distorted both downstream and upstream of any disturbance.

In a pipe, liquid at the edge of the pipe moves slower than towards the center because of friction along the walls.

In a straight run of pipe, area with similar velocities can be depicted as concentric rings.

Theoretical Velocity Profile

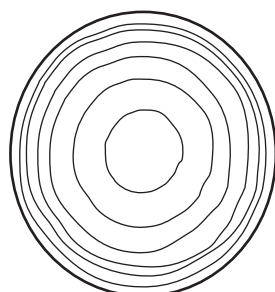

cross section



side view

Flow Sensor Installation

The next diagram depicts the distortion in the velocity profile that occurs just after the flow has gone through an elbow or a tee junction.

The liquid on one side of the profile is moving much faster than in the rest of the pipe.

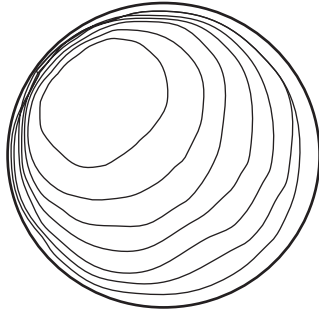

Typical distorted flow velocity patterns related to different disturbances present in the pipeline:

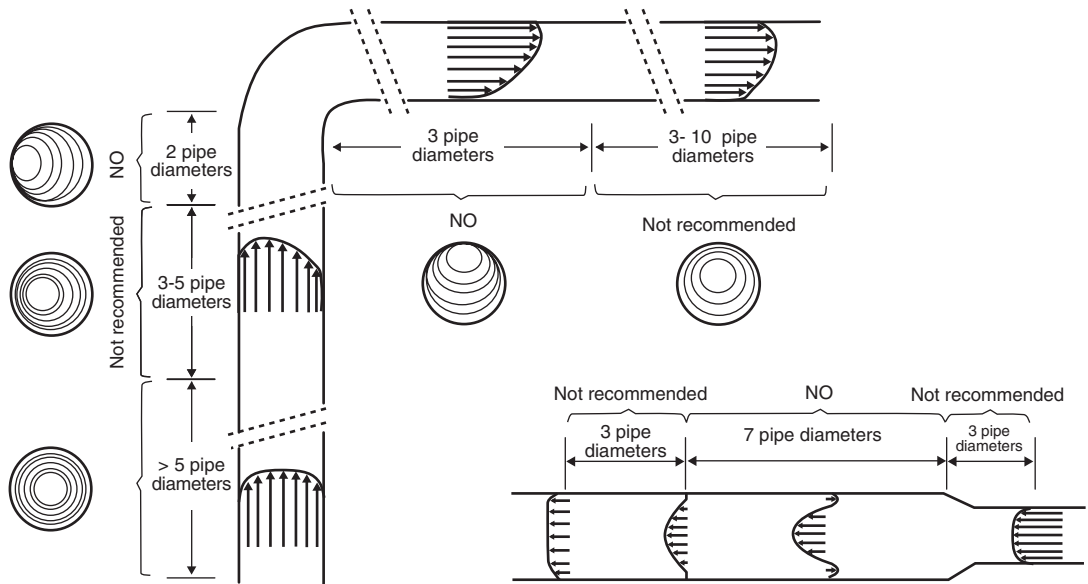

Installation Guidelines

- The six most common installation configurations are shown to help in selecting the best location in the pipeline for paddlewheel flow sensor.
- For more information, please refer to EN ISO 5167-1.
- Always maximize distance between flow sensors and pumps.

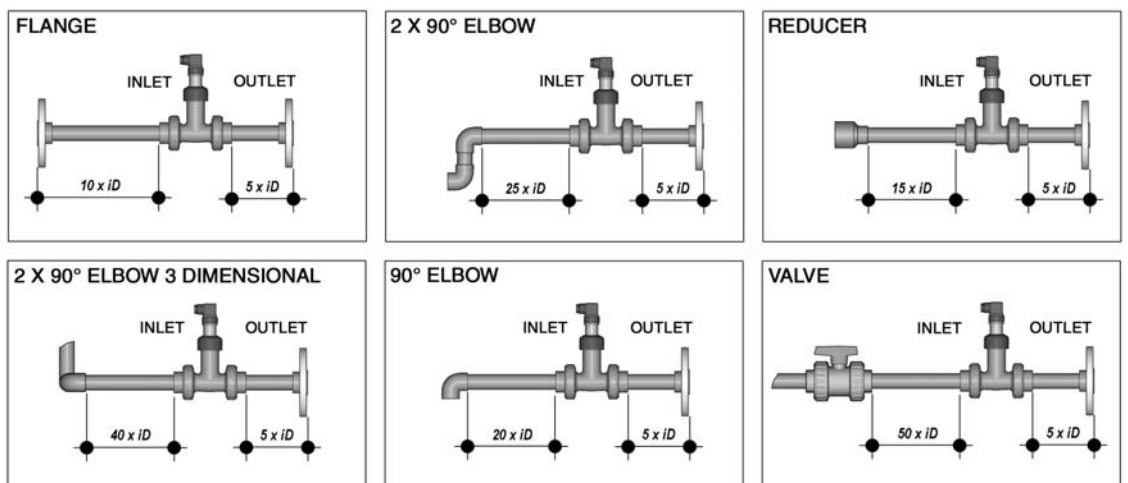

Velocity / Flow rate Conversion Tables

		Flow Rate [l/s] x 1273.2											Velocity [m/s] x ID ²							
Velocity [m/s] =		ID ²											Flow Rate [l/s] =				1273.2			
		Velocity																		
		ft/sec	0.5	0.7	1.6	2.6	3.3	4.9	6.6	8.2	9.8	13.1	16.4	20	23	26.2				
		m/s	0.15	0.2	0.5	0.8	1	1.5	2	2.5	3	4	5	6	7	8				
D [mm]	DN [mm]	Flow Rate l/s																		
20	15	0.03	0.04	0.09	0.14	0.18	0.27	0.35	0.44	0.53	0.71	0.88	1.06	1.24	1.41					
25	20	0.05	0.06	0.16	0.25	0.31	0.47	0.63	0.79	0.94	1.26	1.57	1.89	2.20	2.51					
32	25	0.07	0.10	0.25	0.39	0.49	0.74	0.98	1.23	1.47	1.96	2.45	2.95	3.44	3.93					
40	32	0.12	0.16	0.40	0.64	0.80	1.21	1.61	2.01	2.41	3.22	4.02	4.83	5.63	6.43					
50	40	0.19	0.25	0.63	1.01	1.26	1.89	2.51	3.14	3.77	5.03	6.28	7.54	8.80	10.05					
63	50	0.29	0.39	0.98	1.57	1.96	2.95	3.93	4.91	5.89	7.85	9.82	11.78	13.74	15.71					
75	65	0.50	0.66	1.66	2.65	3.32	4.98	6.64	8.30	9.96	13.27	16.59	19.91	23.23	26.55					
90	80	0.75	1.01	2.51	4.02	5.03	7.54	10.05	12.57	15.08	20.11	25.13	30.16	35.19	40.21					
110	100	1.18	1.57	3.93	6.28	7.85	11.78	15.71	19.64	23.56	31.42	39.27	47.13	54.98	62.83					
125	110	1.43	1.90	4.75	7.60	9.50	14.26	19.01	23.76	28.51	38.01	47.52	57.02	66.53	76.03					
140	125	1.84	2.45	6.14	9.82	12.27	18.41	24.54	30.68	36.82	49.09	61.36	73.63	85.91	98.18					
160	150	2.65	3.53	8.84	14.14	17.67	26.51	35.34	44.18	53.02	70.69	88.36	106.03	123.70	141.38					
200	180	3.82	5.09	12.72	20.36	25.45	38.17	50.90	63.62	76.34	101.79	127.24	152.69	178.13	203.58					
225	200	4.71	6.28	15.71	25.13	31.42	47.13	62.83	78.54	94.25	125.67	157.08	188.50	219.92	251.34					
250	225	5.96	7.95	19.88	31.81	39.76	59.64	79.52	99.41	119.29	159.05	198.81	238.57	278.33	318.10					
280	250	7.36	9.82	24.54	39.27	49.09	73.63	98.18	122.72	147.27	196.36	245.44	294.53	343.62	392.71					
315	300	10.60	14.14	35.34	56.55	70.69	106.03	141.38	176.72	212.06	282.75	353.44	424.13	494.82	565.50					
400	350	14.43	19.24	48.11	76.97	96.21	144.32	192.43	240.54	288.64	384.86	481.07	577.29	673.50	769.71					
450	400	18.85	25.13	62.83	100.53	125.67	188.50	251.34	314.17	377.00	502.67	628.34	754.01	879.67	1005.34					
500	450	23.86	31.81	79.52	127.24	159.05	238.57	318.10	397.62	477.14	636.19	795.24	954.29	1113.34	1272.38					

		Flow Rate [l/m] x 21.16											Velocity [m/s] x ID ²							
Velocity [m/s] =		ID ²											Flow Rate [l/m] =				21.16			
		Velocity																		
		ft/sec	0.5	0.7	1.6	2.6	3.3	4.9	6.6	8.2	9.8	13.1	16.4	20	23	26.2				
		m/s	0.15	0.2	0.5	0.8	1	1.5	2	2.5	3	4	5	6	7	8				
D [mm]	DN [mm]	Flow Rate l/m																		
20	15	1.6	2.1	5.3	8.5	10.6	15.9	21.3	26.6	31.9	42.5	53.2	63.8	74.4	85.1					
25	20	2.8	3.8	9.5	15.1	18.9	28.4	37.8	47.3	56.7	75.6	94.5	113.4	132.3	151.2					
32	25	4.4	5.9	14.8	23.6	29.5	44.3	59.1	73.8	88.6	118.1	147.7	177.2	206.8	236.3					
40	32	7.3	9.7	24.2	38.7	48.4	72.6	96.8	121.0	145.2	193.6	242.0	290.4	338.8	387.1					
50	40	11.3	15.1	37.8	60.5	75.6	113.4	151.2	189.0	226.8	302.5	378.1	453.7	529.3	604.9					
63	50	17.7	23.6	59.1	94.5	118.1	177.2	236.3	295.4	354.4	472.6	590.7	708.9	827.0	945.2					
75	65	30.0	39.9	99.8	159.7	199.7	299.5	399.3	499.2	599.0	798.7	998.3	1198.0	1397.7	1597.4					
90	80	45.4	60.5	151.2	242.0	302.5	453.7	604.9	756.1	907.4	1209.8	1512.3	1814.7	2117.2	2419.7					
110	100	70.9	94.5	236.3	378.1	472.6	708.9	945.2	1181.5	1417.8	1890.4	2362.9	2835.5	3308.1	3780.7					
125	110	85.8	114.4	285.9	457.5	571.8	857.8	1143.7	1429.6	1715.5	2287.3	2859.2	3431.0	4002.8	4574.7					
140	125	110.8	147.7	369.2	590.7	738.4	1107.6	1476.8	1846.1	2215.3	2953.7	3692.1	4430.5	5169.0	5907.4					
160	150	159.5	212.7	531.7	850.7	1063.3	1595.0	2126.7	2658.3	3190.0	4253.3	5316.6	6380.0	7443.3	8506.6					
200	180	229.7	306.2	765.6	1225.0	1531.2	2296.8	3062.4	3828.0	4593.6	6124.8	7656.0	9187.1	10718.3	12249.5					
225	200	283.6	378.1	945.2	1512.3	1890.4	2835.5	3780.7	4725.9	5671.1	7561.4	9451.8	11342.2	13232.5	15122.9					
250	225	358.9	478.5	1196.2	1914.0	2392.5	3588.7	4785.0	5981.2	7177.5	9569.9	11962.4	14354.9	16747.4	19139.9					
280	250	443.1	590.7	1476.8	2362.9	2953.7	4430.5	5907.4	7384.2	8861.1	11814.7	14768.4	17722.1	20675.8	23629.5					
315	300	638.0	850.7	2126.7	3402.6	4253.3	6380.0	8506.6	10633.3	12759.9	17013.2	21266.5	25519.8	29773.2	34026.5					
400	350	868.4	1157.8	2894.6	4631.4	5789.2	8683.8	11578.4	14473.1	17367.7	23156.9	28946.1	34735.3	40524.6	46313.8					
450	400	1134.2	1512.3	3780.7	6049.1	7561.4	11342.2	15122.9	18903.6	22684.3	30245.7	37807.2	45368.6	52930.1	60491.5					
500	450	1435.5	1914.0	4785.0	7656.0	9569.9	14354.9	19139.9	23924.9	28709.8	38279.8	47849.7	57419.7	66989.6	76559.5					

Velocity / Flow rate Conversion Tables

		Flow Rate [l/h] x 0.35344							Velocity [m/s] x ID ²													
Velocity [m/s] =		ID ²							Flow Rate [l/h] =							0.35344						
		Velocity																				
		ft/sec	0.5	0.7	1.6	2.6	3.3	4.9	6.6	8.2	9.8	13.1	16.4	20	23	26.2						
		m/s	0.15	0.2	0.5	0.8	1	1.5	2	2.5	3	4	5	6	7	8						
D [mm]	DN [mm]	Flow Rate l/h																				
20	15	95	127	318	509	637	955	1273	1592	1910	2546	3183	3820	4456	5093							
25	20	170	226	566	905	1132	1698	2263	2829	3395	4527	5659	6790	7922	9054							
32	25	265	354	884	1415	1768	2653	3537	4421	5305	7073	8842	10610	12378	14147							
40	32	435	579	1449	2318	2897	4346	5794	7243	8692	11589	14486	17383	20281	23178							
50	40	679	905	2263	3622	4527	6790	9054	11317	13581	18108	22635	27162	31689	36215							
63	50	1061	1415	3537	5659	7073	10610	14147	17683	21220	28293	35367	42440	49513	56587							
75	65	1793	2391	5977	9563	11954	17931	23908	29885	35862	47816	59770	71724	83678	95632							
90	80	2716	3622	9054	14486	18108	27162	36215	45269	54323	72431	90539	108646	126754	144862							
110	100	4244	5659	14147	22635	28293	42440	56587	70733	84880	113173	141467	169760	198053	226347							
125	110	5135	6847	17117	27388	34235	51352	68470	85587	102705	136940	171175	205410	239645	273880							
140	125	6631	8842	22104	35367	44208	66313	88417	110521	132625	176833	221042	265250	309458	353667							
160	150	9549	12732	31830	50928	63660	95490	127320	159150	190980	254640	318300	381960	445620	509280							
200	180	13751	18334	45835	73336	91670	137506	183341	229176	275011	366682	458352	550023	641693	733364							
225	200	16976	22635	56587	90539	113173	169760	226347	282933	339520	452694	565867	679040	792214	905387							
250	225	21485	28647	71618	114588	143235	214853	286470	358088	429705	572940	716175	859410	1002645	1145880							
280	250	26525	35367	88417	141467	176833	265250	353667	442084	530500	707334	884167	1061000	1237834	1414667							
315	300	38196	50928	127320	203712	254640	381960	509280	636600	763920	1018560	1273201	1527841	1782481	2037121							
400	350	51989	69319	173297	277275	346593	519890	693187	866484	1039780	1386374	1732967	2079561	2426154	2772748							
450	400	67904	90539	226347	362155	452694	679040	905387	1131734	1358081	1810774	2263468	2716161	3168855	3621548							
500	450	85941	114588	286470	458352	572940	859410	1145880	1432351	1718821	2291761	2864701	3437641	4010582	4583522							

		Flow Rate [m ³ /h] x 353.44							Velocity [m/s] x ID ²													
Velocity [m/s] =		ID ²							Flow Rate [m ³ /h] =							353.44						
		Velocity																				
		ft/sec	0.5	0.7	1.6	2.6	3.3	4.9	6.6	8.2	9.8	13.1	16.4	20	23	26.2						
		m/s	0.15	0.2	0.5	0.8	1	1.5	2	2.5	3	4	5	6	7	8						
D [mm]	DN [mm]	Flow Rate m ³ /h																				
20	15	0.10	0.13	0.32	0.51	0.64	0.95	1.27	1.59	1.91	2.55	3.18	3.82	4.46	5.09							
25	20	0.17	0.23	0.57	0.91	1.13	1.70	2.26	2.83	3.40	4.53	5.66	6.79	7.92	9.05							
32	25	0.27	0.35	0.88	1.41	1.77	2.65	3.54	4.42	5.31	7.07	8.84	10.61	12.38	14.15							
40	32	0.43	0.58	1.45	2.32	2.90	4.35	5.79	7.24	8.69	11.59	14.49	17.38	20.28	23.18							
50	40	0.68	0.91	2.26	3.62	4.53	6.79	9.05	11.32	13.58	18.11	22.63	27.16	31.69	36.22							
63	50	1.06	1.41	3.54	5.66	7.07	10.61	14.15	17.68	21.22	28.29	35.37	42.44	49.51	56.59							
75	65	1.79	2.39	5.98	9.56	11.95	17.93	23.91	29.88	35.86	47.82	59.77	71.72	83.68	95.63							
90	80	2.72	3.62	9.05	14.49	18.11	27.16	36.22	45.27	54.32	72.43	90.54	108.65	126.75	144.86							
110	100	4.24	5.66	14.15	22.63	28.29	42.44	56.59	70.73	84.88	113.17	141.47	169.76	198.05	226.35							
125	110	5.14	6.85	17.12	27.39	34.23	51.35	68.47	85.59	102.70	136.94	171.17	205.41	239.64	273.88							
140	125	6.63	8.84	22.10	35.37	44.21	66.31	88.42	110.52	132.63	176.83	221.04	265.25	309.46	353.67							
160	150	9.55	12.73	31.83	50.93	63.66	95.49	127.32	159.15	190.98	254.64	318.30	381.96	445.62	509.28							
200	180	13.75	18.33	45.84	73.34	91.67	137.51	183.34	229.18	275.01	366.68	458.35	550.02	641.69	733.36							
225	200	16.98	22.63	56.59	90.54	113.17	169.76	226.35	282.93	339.52	452.69	565.87	679.04	792.21	905.39							
250	225	21.49	28.65	71.62	114.59	143.24	214.85	286.47	358.09	429.71	572.94	716.18	859.41	1002.65	1145.88							
280	250	26.53	35.37	88.42	141.47	176.83	265.25	353.67	442.08	530.50	707.33	884.17	1061.00	1237.83	1414.67							
315	300	38.20	50.93	127.32	203.71	254.64	381.96	509.28	636.60	763.92	1018.56	1273.20	1527.84	1782.48	2037.12							
400	350	51.99	69.32	173.30	277.27	346.59	519.89	693.19	866.48	1039.78	1386.37	1732.97	2079.56	2426.15	2772.75							
450	400	67.90	90.54	226.35	362.15	452.69	679.04	905.39	1131.73	1358.08	1810.77	2263.47	2716.16	3168.85	3621.55							
500	450	85.94	114.59	286.47	458.35	572.94	859.41	1145.88	1432.35	1718.82	2291.76	2864.70	3437.64	4010.58	4583.52							

Velocity / Flow rate Conversion Tables

Velocity [f/s] = $\frac{\text{Flow Rate [gpm]} \times 0.4085}{ID^2}$		Flow Rate [gpm] = $\frac{\text{Velocity [f/s]} \times ID^2}{0.4085}$														
		Velocity														
		ft/sec	0.5	0.7	1.6	2.6	3.3	4.9	6.6	8.2	9.8	13.1	16.4	20	23	26.2
		m/s	0.15	0.2	0.5	0.8	1	1.5	2	2.5	3	4	5	6	7	8
D [inch]	DN [mm]	Flow Rate US-gpm														
1/2	15	0.4	0.6	1.4	2.2	2.8	4.2	5.6	7.0	8.4	11.2	14.0	16.9	19.7	22.5	
3/4	20	0.7	1.0	2.5	4.0	5.0	7.5	10.0	12.5	15.0	20.0	25.0	30.0	35.0	40.0	
1	25	1.2	1.6	3.9	6.2	7.8	11.7	15.6	19.5	23.4	31.2	39.0	46.8	54.6	62.4	
1 1/4	32	1.9	2.6	6.4	10.2	12.8	19.2	25.6	32.0	38.4	51.1	63.9	76.7	89.5	102.3	
1 1/2	40	3.0	4.0	10.0	16.0	20.0	30.0	40.0	49.9	59.9	79.9	99.9	119.9	139.8	159.8	
2	50	4.7	6.2	15.6	25.0	31.2	46.8	62.4	78.0	93.6	124.8	156.1	187.3	218.5	249.7	
2 1/2	65	7.9	10.5	26.4	42.2	52.7	79.1	105.5	131.9	158.2	211.0	263.7	316.5	369.2	422.0	
3	80	12.0	16.0	40.0	63.9	79.9	119.9	159.8	199.8	239.7	319.6	399.5	479.4	559.3	639.2	
4	100	18.7	25.0	62.4	99.9	124.8	187.3	249.7	312.1	374.5	499.4	624.2	749.1	873.9	998.8	
5	125	29.3	39.0	97.5	156.1	195.1	292.6	390.1	487.7	585.2	780.3	975.4	1170.4	1365.5	1560.6	
6	150	42.1	56.2	140.5	224.7	280.9	421.4	561.8	702.3	842.7	1123.6	1404.5	1685.4	1966.3	2247.2	
8	200	74.9	99.9	249.7	399.5	499.4	749.1	998.8	1248.5	1498.1	1997.5	2496.9	2996.3	3495.7	3995.0	
10	225	94.8	126.4	316.0	505.6	632.0	948.0	1264.1	1580.1	1896.1	2528.1	3160.1	3792.2	4424.2	5056.2	
12	300	168.5	224.7	561.8	898.9	1123.6	1685.4	2247.2	2809.0	3370.8	4494.4	5618.0	6741.6	7865.2	8988.8	
14	350	229.4	305.9	764.7	1223.5	1529.4	2294.0	3058.7	3823.4	4588.1	6117.4	7646.8	9176.1	10705.5	12234.8	
16	400	299.6	399.5	998.8	1598.0	1997.5	2996.3	3995.0	4993.8	5992.6	7990.1	9987.6	11985.1	13982.6	15980.2	
18	450	379.2	505.6	1264.1	2022.5	2528.1	3792.2	5056.2	6320.3	7584.3	10112.5	12640.6	15168.7	17696.8	20224.9	

Main Conversion Factors

	To convert	Into	Multiply by	
VOLUME	US Gallon	fl. oz. (U.S.)	128	
		cubic inch	231	
		cubic ft.	0.134	
		liter	3.785	
		cubic meter	0.00379	
		Imp. gallon	0.833	
		pound	8.33	
		Imperial Gallon	U.S. gallon	1.2
		Cubic Foot	U.S. gallon	7.48
			Cubic meter	0.0283
		Liter	U.S. gallon	0.2642
		Cubic meter	cubic ft.	35.314
	U.S. gallon	264.2		
LENGTH	Inch	centimeter	2.5400	
		Foot	meter	0.3048
		Yard	meter	0.9144
		Mile	kilometer	1.6093
WEIGHT	Ounce	gram	28.3495	
		Pound	gram	453.59
FLOW RATE	US gallon per minute (gpm)	liter per second	0.063	
		US gallon per minute (gpm)	cubic meter per hr.	0.227
		UK gallon per minute (gpm)	cubic meter per hr.	0.273
PRESSURE	Atmosphere	bar	1.0133	
		Psi [lb/inch ²]	bar	0.0689
		Pascal [Newton/m ²]	bar	10 ⁻⁵
		MegaPascal	bar	10
TEMPERATURE	Kelvin [°K]	celsius [°C]	°C = °K - 273	
		Fahrenheit [°F]	celsius [°C]	°C = (°F - 32) x 5/9